

# AKU EKO



**NEW!**



Acoustically insulated fans

Akustiniai kanaliniai ventiliatoriai

Wentylatory izolowane akustycznie

Канальные акустические вентиляторы

SALDA

ACOUSTICALLY INSULATED FANS



Acoustically insulated duct fans are made of galvanized steel. The fan casing has thermal and acoustic 50 mm insulation. These products can not be exploited in explosive environment and they can supply/extract only clean air. Centrifugal fans with EC motors with maintenance free ball bearings are used for the AKU EKO fans. Fans with EC motors are characterized by high efficiency and high static pressure.

The equipment has easily opening cover. It allows easy maintenance. The continuous control of motor speed is optionally provided. The speed of EC motors may be changed by connecting 10 kΩ potentiometer to the control circuit. This simplifies way the electrical connection is avoiding the need of expensive and large dimension speed regulators. The speed may be set via an external signal 0-10 VDC.

The maximum motor current and the rated power supply voltage are marked on the data plate, attached to the unit.

Acoustically insulated fans can be mounted only indoors.



Kanaliniai akustiniai ventiliatoriai, pasižymi žemu triukšmo lygiu įsiurbimo kanale ir į aplinką. Apžiūros dangtis lengvai atidaromas ir prie korpuso tvirtinamas vyriais ir užraktais, todėl ventiliatorių lengva prižiūrėti bei valyti. Nenaudojami užteršto oro, agresyvių, sprogių dujų transportavimui.

Sparnuotė: atgal lenktais sparneliais.

Variklis: išorinis rotorius (EC), tiesioginė pavara, integruota termokontaktinė variklio apsauga, ilgai tarnaujantys, nereikalaujantys priežiūros guoliai. Ventiliatoriai su EC varikliu pasižymi efektyvumu ir aukštu slėgiu.

Nuoseklus variklio valdymas komplektuojamas papildomai. Variklio greitis keičiamas į valdymo grandinę prijungus 10kΩ potenciometrą. Tai leidžia supaprastinti elektros jungimą ir išvengti brangių greičio reguliatorių. Taip pat greitis gali būti nustatomas išoriniu signalu 0-10VDC.

Korpusas: iš cinkuotos skardos

Garso izoliacija: akmens vatos, akmens vatos su sustiprintu paviršiumi, 50mm storio, nedegi.



Wentylatory izolowane akustycznie wykonane są z ocynkowanej blachy stalowej malowanej proszkowo. Obudowa wentylatora posiada izolację termiczną i akustyczną grubości 50 mm. Nie nadają się do zastosowań w środowiskach agresywnych chemicznie oraz zagrożonych wybuchem. Nie zaleca się stosować w instalacjach zanieczyszczonych cząstkami stałymi, pyłami i odpadami technologicznymi.

Nie stosować w instalacjach oddymiania, przeciwpożarowych, spalinowych. Wentylatory są przeznaczone do montażu w systemach kanałowych o przekroju kołowym/prostokątnym.

Wentylatory promieniowe z silnikami EC z bezobrotowymi łożyskami kulkowymi. Wentylatory z silnikami EC charakteryzują się wysoką wydajnością i wysokim ciśnieniem statycznym.

Wentylatory wyposażone w otwieraną pokrywę, umożliwiającą łatwą konserwację.

Płynna regulacja prędkości silnika jest możliwa dzięki regulatorom prędkości silników EC.

Maksymalny prąd silnika i napięcie znamionowe zasilania są oznaczone na tabliczce znamionowej znajdującej się na urządzeniu.

Wentylatory izolowane akustycznie mogą być montowane tylko w pomieszczeniach.



Канальные акустические вентиляторы изготавливаются из оцинкованной жести. Корпус вентиляторов имеет 50 мм слой термической и акустической изоляции. Данные изделия не могут работать во взрывоопасной среде, они предназначены для подачи / вытяжки только чистого воздуха. Монтируется в системы круглых воздуховодов. В вентиляторах АКУ ЕКО используются центробежные вентиляторы, подшипники ЕС-двигателей которые не требуют ухода. Вентиляторы с ЕС-двигателями отличаются большой эффективностью и высоким статическим давлением.

Обзорная крышка устройства открывается легко, что обеспечивает удобное обслуживание.

Возможно плавное управление скоростью двигателя. Изменять скорость ЕС-двигателей можно путем включения в цепь управления потенциометра 10 кОм. Это облегчает электрическое подключение и не требует дорогих и громоздких регуляторов скорости. Скорость также можно изменять внешним сигналом 10VDC.

Максимальный ток и мощность двигателей указаны рядом с номинальным напряжением питания.

Акустические вентиляторы монтируются только в закрытых помещениях.

## Accessories

0-10V speed controller	Mounting clamp	Guard grille	Back draft shutter	Circular duct silencer	Filter cassette
					
MTP010 p. 142	AP p. 152	AGO p. 212	RSK p. 205	AKS p. 198	FD p. 191

AKU 120 - 315 EKO

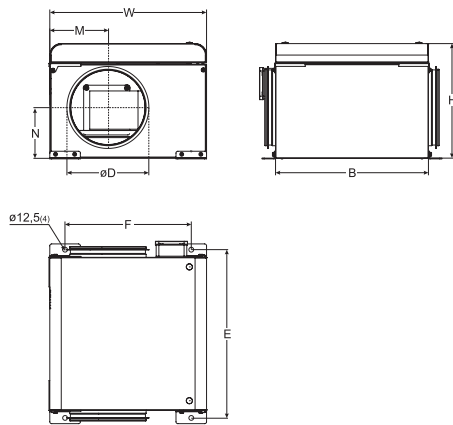

AKU 500 x 250 - 700 x 400S EKO

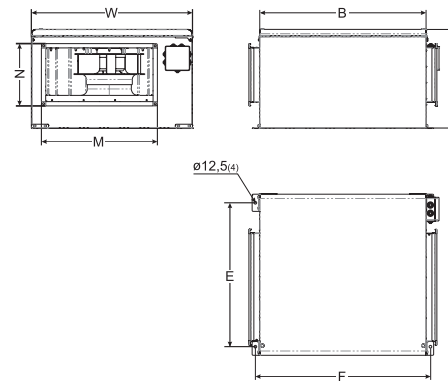

Type	Dimensions [mm]							
	B	W	H	M	N	øD	E	F
AKU 125 EKO	400	410	325	205	165,5	125	440	330
AKU 160 EKO	550	485	340	149	193	160	590	405
AKU 200 EKO	600	545	425	170	259,5	200	640	465
AKU 250 EKO	600	545	425	194	234,5	250	640	465
AKU 315 EKO	437	595	475	297,5	238	315	477	515
AKU 500x250 EKO	775	750	460	500	250	-	670	815
AKU 700x400 EKO	650	950	570	700	400	-	870	690
AKU 700x400S EKO	650	950	570	700	400	-	870	690

Type	Accessories												
	MTP010	AP	AGO	RSK	AKS	SKS	FD	FDI	FDS	EKA	EKS	AVS	SVS
AKU 125 EKO	MTP010	125	125	125	125	-	125	125	-	125	-	125	-
AKU 160 EKO	MTP010	160	160	160	160	-	160	160	-	160	-	160	-
AKU 200 EKO	MTP010	200	200	200	200	-	200	200	-	200	-	200	-
AKU 250 EKO	MTP010	250	250	250	250	-	250	250	-	250	-	250	-
AKU 315 EKO	MTP010	315	315	315	315	-	315	315	-	315	-	315	-
AKU 500x250 EKO	MTP010	-	-	-	-	500x250	-	-	500x250	-	500x250	-	500x250
AKU 700x400 EKO	MTP010	-	-	-	-	700x400	-	-	700x400	-	700x400	-	700x400
AKU 700x250S EKO	MTP010	-	-	-	-	700x400	-	-	700x400	-	700x400	-	700x400

## Accessories



# AKU EKO

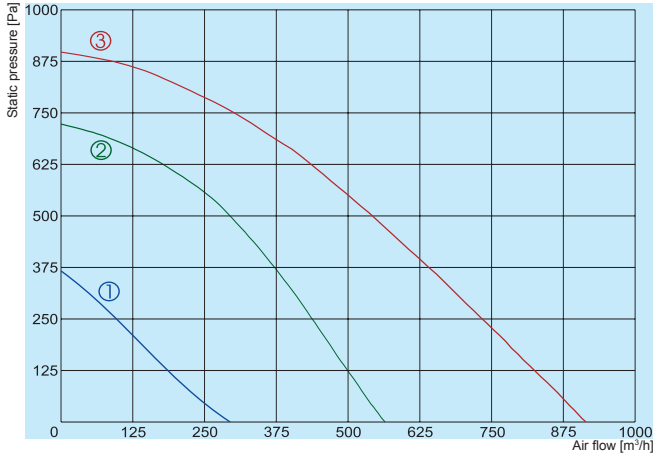

- ① — AKU 125 EKO
- ② — AKU 160 EKO
- ③ — AKU 200 EKO

		125 EKO	160 EKO	200 EKO
Voltage/Frequency	[V/Hz]	~1, 230	~1, 230	~1, 230
Power consumption	[kW]	0,053	0,111	0,192
Current	[A]	0,4	0,88	1,42
Speed	[min <sup>-1</sup> ]	4480	3490	3380
Max. airflow	[m³/h]	296	577	900
Min./Max. air temperature	[°C]	-25/60	-25/60	-25/60
Weight	[kg]	12,0	19,0	24,0
Wiring diagram		No. 1	No. 1	No. 1
Protection class:	motor	IP-44	IP-44	IP-44
	terminal box	IP-55	IP-55	IP-55
Impeller		backwards curved	backwards curved	backwards curved
Inlet		single	single	single
Comply with ERP 2013; 2015		+	+	+

## 125 EKO

	LWA total, dB(A)	Lwa, dB(A)						
		125 Hz	250 Hz	500 Hz	1 kHz	2 kHz	4 kHz	8 kHz
Inlet	59	41	54	56	45	45	40	44
Outlet	65	43	58	62	57	57	52	49
Surrounding	47	28	43	44	36	34	31	29

Measured at 207 m³/h, 95 Pa

## 160 EKO

	LWA total, dB(A)	Lwa, dB(A)						
		125 Hz	250 Hz	500 Hz	1 kHz	2 kHz	4 kHz	8 kHz
Inlet	65	49	63	60	49	51	48	46
Outlet	74	52	68	70	67	64	61	58
Surrounding	54	36	52	49	42	41	38	36

Measured at 413 m³/h, 211 Pa

## 200 EKO

	LWA total, dB(A)	Lwa, dB(A)						
		125 Hz	250 Hz	500 Hz	1 kHz	2 kHz	4 kHz	8 kHz
Inlet	68	52	66	60	56	54	51	52
Outlet	80	56	74	76	74	69	64	63
Surrounding	58	39	56	52	49	45	41	42

Measured at 805 m³/h, 170 Pa

The fan characteristic curves were determined in accordance with EN ISO 5801. The sound levels were determined in accordance with DIN 45635 resp. ISO 3744 at a distance of 1 m from the fan.

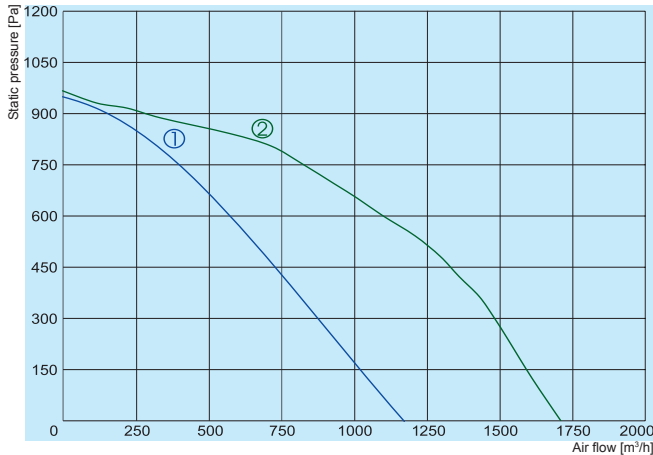

- ① — AKU 250 EKO
- ② — AKU 315 EKO

		<b>250 EKO</b>	<b>315 EKO</b>
Voltage/Frequency	[V/Hz]	~1, 230	~1, 230
Power consumption	[kW]	0,225	0,400
Current	[A]	1,74	3,0
Speed	[min <sup>-1</sup> ]	3220	3400
Max. airflow	[m <sup>3</sup> /h]	1167	1642
Min./Max. air temperature	[°C]	-25/60	-25/55
Weight	[kg]	24,0	31,0
Wiring diagram		No. 1	No. 2
Protection class:	motor	IP-44	IP-54
	terminal box	IP-55	IP-55
Impeller		backwards curved	backwards curved
Inlet		single	single
Comply with ERP 2013; 2015		+	+

### 250 EKO

	Lwa total, dB(A)	Lwa, dB(A)						
		125 Hz	250 Hz	500 Hz	1 kHz	2 kHz	4 kHz	8 kHz
Inlet	73	57	70	64	66	59	53	52
Outlet	84	62	77	80	78	73	68	64
Surrounding	63	45	60	56	56	49	44	42

Measured at 1049 m<sup>3</sup>/h, 120 Pa

### 315 EKO

	Lwa total, dB(A)	Lwa, dB(A)						
		125 Hz	250 Hz	500 Hz	1 kHz	2 kHz	4 kHz	8 kHz
Inlet	76	59	73	67	68	65	58	55
Outlet	87	64	75	84	81	76	72	67
Surrounding	65	47	61	60	58	54	48	45

Measured at 1553 m<sup>3</sup>/h, 120 Pa

The fan characteristic curves were determined in accordance with EN ISO 5801. The sound levels were determined in accordance with DIN 45635 resp. ISO 3744 at a distance of 1 m from the fan.

# AKU EKO

SALDA

ACOUSTICALLY INSULATED FANS

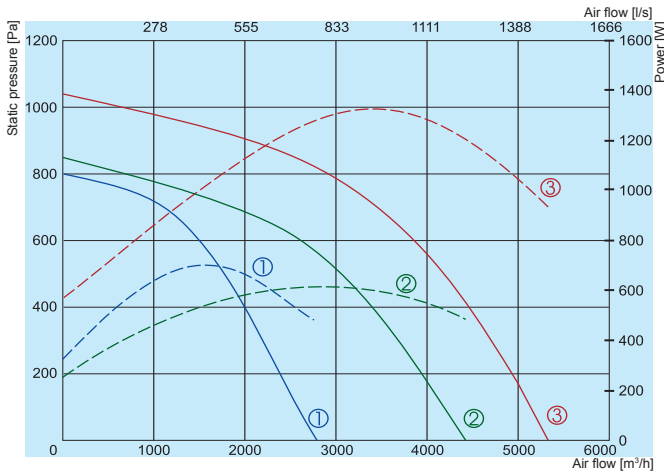

**NEW!**

- ① AKU 500x250 EKO
- ② AKU 700x400 EKO
- ③ AKU 700x400S EKO

— Performance  
- - - Power consumption



		500x250 EKO	700x400 EKO	700x400S EKO
Voltage/Frequency	[V/Hz]	230/50	230/50	230/50
Power consumption	[kW]	0,540	0,95	1,330
Current	[A]	2,48	4,3	5,8
Speed	[min <sup>-1</sup> ]	2600	2200	2390
Max. airflow	[m <sup>3</sup> /h]	2805	4436	5313
Min./Max. air temperature	[°C]	-25/40	-15/60	-25/40
Weight	[kg]	52,0	49,7	51,3
Wiring diagram		No.3	No.4	No.4
Protection class:	motor	IP-54	IP-54	IP-54
	terminal box	IP-55	IP-55	IP-55
Impeller		backwards curved	backwards curved	backwards curved
Inlet		single	single	single
Comply with ERP 2013;2015		+	+	+

500x250 EKO	Lwa total, dB(A)	Lwa, dB(A)						
		125 Hz	250 Hz	500 Hz	1 kHz	2 kHz	4 kHz	8 kHz
Inlet	79	62	75	73	73	67	63	58
Outlet	90	66	81	87	83	81	77	70
Surrounding	69	49	64	64	62	57	53	48
Measured at 2529 m <sup>3</sup> /h, 116 Pa								
700x400 EKO	Lwa total, dB(A)	Lwa, dB(A)						
		125 Hz	250 Hz	500 Hz	1 kHz	2 kHz	4 kHz	8 kHz
Inlet	79	59	68	68	75	69	67	63
Outlet	85	62	72	72	78	78	75	66
Surrounding	66	66	46	56	61	57	54	49
Measured at 4135 m <sup>3</sup> /h, 121 Pa								
700x400S EKO	Lwa total, dB(A)	Lwa, dB(A)						
		125 Hz	250 Hz	500 Hz	1 kHz	2 kHz	4 kHz	8 kHz
Inlet	83	56	73	78	76	75	73	69
Outlet	89	59	77	81	85	82	80	73
Surrounding	71	48	62	64	66	63	61	55
Measured at 5102 m <sup>3</sup> /h, 101 Pa								

The fan characteristic curves were determined in accordance with EN ISO 5801. The sound levels were determined in accordance with DIN 45635 resp. ISO 3744 at a distance of 1 m from the fan.

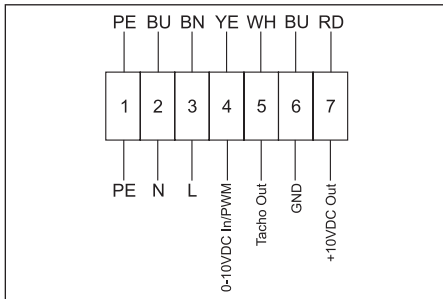

**Wiring diagram No. 1 (1~230V)**

- PE - yellow-green
- BU - blue
- BN - brown
- YE - yellow
- WH - white
- RD - red

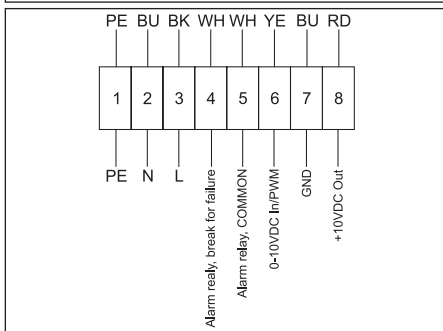

**Wiring diagram No. 2 (1~230V)**

- PE - yellow-green
- BU - blue
- BN - brown
- YE - yellow
- WH - white
- RD - red

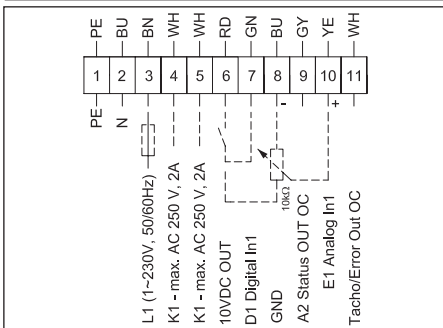

**Wiring diagram No. 3 (1~230V)**

- PE - yellow-green
- BU - blue
- BN - brown
- YE - yellow
- WH - white
- RD - red
- GN - green
- BU - blue
- GY - grey

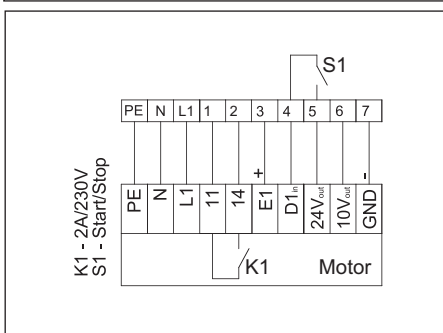

**Wiring diagram No. 4 (1~230V)**